

(12) INTERNATIONAL APPLICATION PUBLISHED UNDER THE PATENT COOPERATION TREATY (PCT)

(19) World Intellectual Property Organization
International Bureau



(43) International Publication Date
19 December 2002 (19.12.2002)

PCT

(10) International Publication Number
WO 02/101359 A2

- (51) International Patent Classification⁷: G01N [DE/US]; 1652 Castilleja, Palo Alto, CA 94306 (US). FREEMAN, Dominique, M. [GB/US]; 4545 La Honda Road, La Honda, CA 94020 (US). MAUZE, Ganapati [US/US]; 1114 W. Knickerbocker Drive, Sunnyvale, CA 94087 (US).
- (21) International Application Number: PCT/US02/19059
- (22) International Filing Date: 12 June 2002 (12.06.2002)
- (25) Filing Language: English
- (26) Publication Language: English
- (30) Priority Data: 60/297,864 12 June 2001 (12.06.2001) US
- (63) Related by continuation (CON) or continuation-in-part (CIP) to earlier application: US 60/297,864 (CIP) Filed on 12 June 2001 (12.06.2001)
- (74) Agent: TUNG, Hao, Y.; Heller Ehrman White & McAuliffe LLP, 275 Middlefield Road, Menlo Park, CA 94025-3506 (US).
- (81) Designated States (*national*): AE, AG, AL, AM, AT, AU, AZ, BA, BB, BG, BR, BY, BZ, CA, CH, CN, CO, CR, CU, CZ, DE, DK, DM, DZ, EC, EE, ES, FI, GB, GD, GE, GH, GM, HR, HU, ID, IL, IN, IS, JP, KE, KG, KP, KR, KZ, LC, LK, LR, LS, LT, LU, LV, MA, MD, MG, MK, MN, MW, MX, MZ, NO, NZ, OM, PH, PL, PT, RO, RU, SD, SE, SG, SI, SK, SL, TJ, TM, TN, TR, TT, TZ, UA, UG, US, UZ, VN, YU, ZA, ZM, ZW.
- (84) Designated States (*regional*): ARIPO patent (GH, GM, KE, LS, MW, MZ, SD, SL, SZ, TZ, UG, ZM, ZW), Eurasian patent (AM, AZ, BY, KG, KZ, MD, RU, TJ, TM), European patent (AT, BE, CH, CY, DE, DK, ES, FI, FR, GB, GR, IE, IT, LU, MC, NL, PT, SE, TR), OAPI patent (BF, BJ, CF, CG, CI, CM, GA, GN, GQ, GW, ML, MR, NE, SN, TD, TG).
- (71) Applicant (*for all designated States except US*): PE-LIKAN TECHNOLOGIES, INC. [US/US]; 1072 East Meadow Circle, Palo Alto, CA 94303 (US).
- (72) Inventors; and
- (75) Inventors/Applicants (*for US only*): BOECKER, Dirk

[Continued on next page]

(54) Title: INTEGRATED BLOOD SAMPLING ANALYSIS SYSTEM WITH MULTI-USE SAMPLING MODULE

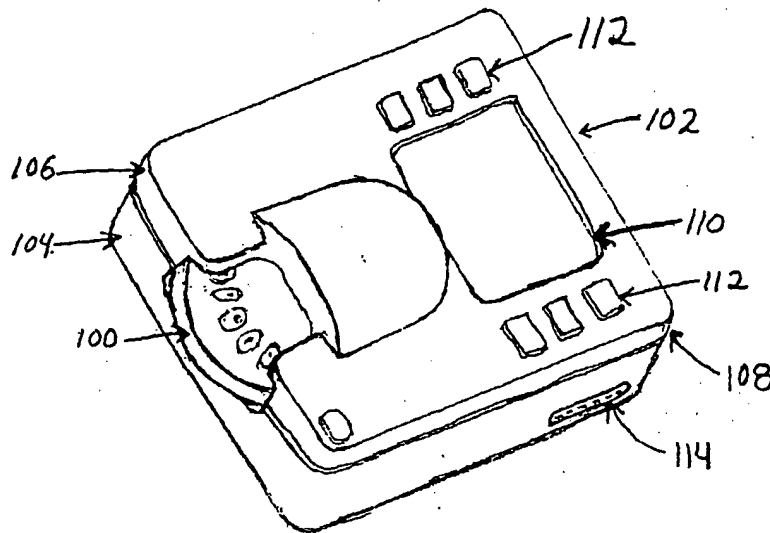

(57) Abstract: A simple, miniaturized, disposable acquisition and test module for monitoring glucose or other analytes successively for multiple times is described. The apparatus is designed to collect and test small volumes of blood in a single step. Many samples can be acquired and analyzed using a single disposable sampling module, minimizing the number of disposables and improving ease of use of the system.

WO 02/101359 A2



**Declaration under Rule 4.17:**

- as to the applicant's entitlement to claim the priority of the earlier application (Rule 4.17(iii)) for the following designations AE, AG, AL, AM, AT, AU, AZ, BA, BB, BG, BR, BY, BZ, CA, CH, CN, CO, CR, CU, CZ, DE, DK, DM, DZ, EC, EE, ES, FI, GB, GD, GE, GH, GM, HR, HU, ID, IL, IN, IS, JP, KE, KG, KP, KR, KZ, LC, LK, LR, LS, LT, LU, LV, MA, MD, MG, MK, MN, MW, MX, MZ, NO, NZ, OM, PH, PL, PT, RO, RU, SD, SE, SG, SI, SK, SL, TJ, TM, TN, TR, TT, TZ, UA, UG, UZ, VN, YU, ZA, ZM, ZW, ARIPO patent (GH, GM, KE, LS, MW, MZ, SD, SL, SZ, TZ, UG, ZM, ZW), Eurasian patent (AM, AZ, BY, KG, KZ, MD, RU, TJ, TM),

European patent (AT, BE, CH, CY, DE, DK, ES, FI, FR, GB, GR, IE, IT, LU, MC, NL, PT, SE, TR); OAPI patent (BF, BJ, CF, CG, CI, CM, GA, GN, GQ, GW, ML, MR, NE, SN, TD, TG)

Published:

- without international search report and to be republished upon receipt of that report

For two-letter codes and other abbreviations, refer to the "Guidance Notes on Codes and Abbreviations" appearing at the beginning of each regular issue of the PCT Gazette.

INTEGRATED BLOOD SAMPLING ANALYSIS SYSTEM WITH
MULTI-USE SAMPLING MODULE

TECHNICAL FIELD

Biochemical analysis of blood samples is an important diagnostic tool for determination of patient status. Analysis of a blood sample for glucose level can provide a powerful tool for diabetics who require tight control of blood glucose levels in an effort to minimize the deleterious long-term effects of the disease. At this time, noninvasive blood analysis technology does not provide the accuracy and specificity required for clinical testing, so that test samples are mainly derived from blood, interstitial fluid, urine or saliva. Many point of care tests are performed directly on capillary whole blood, which is typically obtained by making a small incision on a finger using a hand-held lancing device. The hand-held lancing device usually includes a lancet that is rapidly displaced to penetrate the finger, creating a small wound from which a blood droplet forms on the surface of the skin after the lancet has retracted from the incision.

In addition to the lancet, patients typically deal with numerous other individual components each time a blood test is conducted, e.g. a separate lancet driver, individual testing strips, and a test strip reader. Each time blood testing is performed, the user must prepare the individual components, unwrapping and/or joining them, performing a series of steps to obtain a sample of blood from the lanced skin. Generally, the blood droplet must be placed on a sample assay strip in the proper manner, and the sample assay strip is analyzed using a measurement apparatus, or reader. After each test, the components must then be separated and the disposables (i.e. lancets and test strips) discarded properly.

BACKGROUND ART

The process of acquiring and testing a blood sample using these conventional devices can be painful and often involves numerous steps, the outcome of which is to reduce patient compliance with the frequent self testing regimens required for disease management. In addition to the pain and the paraphernalia required for self-testing, the

success rate of obtaining an adequate blood sample is not 100%. The success rate can be affected by the reproducibility of the lancing technique used (due to variation in skin hydration and thickness, calluses, etc.) as well as the ability to obtain the blood droplet from the incision. Current industry standard lancet and lancing devices can have as low as a 50% success rate in generating a blood sample from the fingertip. The diabetic wishing to adhere to the optimal 5 – 6 times a day self testing regimen would, in essence, need to lance themselves an average of 10 – 12 times just to obtain the blood samples required. The more successful lancing devices are, in reality, about 80 – 90% successful.

What is needed is an improved method for sampling and analyzing bodily fluid which is convenient and cost-efficient resulting in a simplified procedure for extraction and analysis of blood samples at the patient's side.

DISCLOSURE OF INVENTION

Embodiments of the invention relate generally to analysis of bodily fluids. The invention more specifically relates to a disposable sampling module capable of being used multiple times before being discarded.

Embodiments of the invention, including a system for collecting capillary blood are described which incorporates a disposable sampling module. Simplified actuation, lancing, sample acquisition, testing, and readout, are provided all in a handheld apparatus. A sampling module embodiment contains many individual sampling segments, each of which allows the collection and testing of a sample of blood. This allows the sampling module to be used numerous times before exchange with a new module and disposal of the used module becomes necessary, thus reducing the need to dispose of used materials after each test. The sampling module embodiment also retains used sampling materials safely, thereby reducing the problem of handling biohazardous materials.

Previously, it was necessary for the user of a lancet to go through a series of steps to obtain and analyze a blood sample, including preparing components (e.g. lancets, test strips, etc.) cocking a lancet driver, triggering the driver to fire the lancet, manually depositing a blood sample into a sample storage or analysis area, and safe disposal of used testing materials upon completion of the test. The system of

embodiments of the current invention makes the blood collection process more convenient to the user by eliminating the need for the user to repeatedly perform many of these steps.

5 A sampling module embodiment provides for a simplified blood sampling and analysis process by having fewer components requiring assembly by the user and reducing the frequency that the components must be assembled for testing. A single sampling segment combines the lancet and testing means, reducing the task of assembly by the user. The sampling module combines many such sampling segments in unit package that fits cassette-like into a reader device. This multi-use sampling module need 10 only be removed and replaced after all of the sampling segments are used, further reducing the task of assembly (and disassembly and disposal) by the user. In one possible configuration, a lancet driver is provided by a separate apparatus. In other embodiments the lancet driver is included in the reader device or is integrated directly on the sampling module.

15 Techniques for extracting a sample of human blood for the measurement of one or more of its constituents are described, such as might be used for routine monitoring of a chronic condition such as diabetes mellitus. The techniques simplify the extraction and transfer of the blood sample, and reduce the inconvenience of the process. The techniques can be advantageously used in, for example, blood glucose monitoring, 20 coagulation testing, point-of-care stat testing to monitor patient condition over time. The techniques may be used in the clinical setting or for home use or other field settings, such as battlefield, airline, or cruise ship use.

25 One embodiment includes a miniaturized system which may be easily carried by the user, e.g. in a small purse or a jacket pocket. Since sampling is frequently unsuccessful due to obtaining inadequate sample volume, a miniature system to reliably obtain and analyze small samples would improve user acceptance of the sampling procedure.

30 In another embodiment, a method of providing more convenient blood sampling is also described, wherein steps associated with preparation of lancing and testing materials are eliminated or rendered less frequent. In the method, a series of blood samples may be collected and tested using a single disposable sampling module which is designed to couple to a reader device. The sampling module has a plurality of

sampling segments, each sampling segment adapted to be used for a single blood sampling cycle. The method starts with coupling of the sampling module and reader device and then initiating a blood sampling cycle. Upon completion of the blood sampling cycle, the sampling module is advanced to bring a fresh, unused sampling segment online, ready to perform another blood sampling cycle. After a series of blood sampling cycles has been performed and all (or substantially all) of the sampling segments have been used, the sampling module is decoupled from the reader device and discarded, leaving the reader device ready to be coupled with a new sampling module.

BRIEF DESCRIPTION OF DRAWING

The objects, advantages and features of this invention will be more readily appreciated from the following detailed description, when read in conjunction with the accompanying drawing, in which:

Figure 1 illustrates a blood sampling system having features of the current invention.

Figure 2 is a view of the top surface of a sampling module.

Figure 3 schematically depicts a sampling segment of the sampling module in place in the reader device.

BEST MODE FOR CARRYING OUT THE INVENTION

Patents U.S. 3,030,059, U.S. 3,626,929, U.S. 4,360,016, U.S. 4,608,997, U.S. 4,622,974, U.S. 4,627,445, U.S. 4,637,403, U.S. 4,648,408, U.S. 4,653,513, U.S. 4,873,993, U.S. 4,883,068, U.S. 4,895,147, U.S. 4,920,977, WO 97/42882, U.S. 5,047,044, U.S. 5,871,494, U.S. 5,971,941, U.S. 6,071,294, U.S. 6,036,924, U.S. 5,714,390, U.S. 5,801,057, U.S. 5,632,410, U.S. 5,510,266, U.S. 5,500,071, U.S. 5,571,410 and U.S. 5,645,702 are hereby incorporated by reference in their entirety.

It is to be understood that both the foregoing general description and the following detailed description are exemplary and explanatory only and are not restrictive of the invention, as claimed. It must be noted that, as used in the specification and the appended claims, the singular forms "a", "an" and "the" include plural referents unless the context clearly dictates otherwise. Thus, for example, reference to "a material"

includes mixtures of materials, reference to "a chamber" includes multiple chambers, and the like.

In this specification and in the claims which follow, reference will be made to a number of terms which shall be defined to have the following meanings:

5 "Integrated" as used herein means that two or more functions are conducted without intervention by the user: the "integrated" blood sampling system contains the mechanisms for a plurality of functions, e.g., lancing, blood sample collection and testing, conveying information about the sample to the reader device, and advancing the sampling module to bring the next sampling segment online. The group of functions is
10 carried out as the result a single initiating act by the user (i.e. each function does not have to be separately initiated by the user). In the context of a combined reader device/sampling module, integrated means that actuation of the lancet driver, lancing of the skin, sample collection and analysis, display of the test results, and (optionally) advancement of the sampling module to the next position all may occur as the result of
15 a single simple motion by the user, such as pressing the apparatus against the skin to be sampled or touching a button to trigger the lancet driver. In another embodiment, the step of providing a calibration measurement is integrated with the previously mentioned steps. If a device is "configured to allow integrated steps A, B, and C", then steps A, B, and C all follow as a result of a single initiating action. "Unit" when used in relation
20 to the sampling module, or portions of the sampling module, means that the components in the sampling module are assembled into a single housing, so that multiple sampling segments are contained on a single 'unit' device.

"Optional" or "optionally" means that the subsequently described circumstance may or may not occur, so that the description includes instances where the circumstance
25 occurs and instances where it does not. For example, if a device optionally contains a feature for analyzing a blood sample, this means that the analysis feature may or may not be present, and, thus, the description includes structures wherein a device possesses the analysis feature and structures wherein the analysis feature is not present.

"Testing means" refers to any use, singly or in combination, of chemical test
30 reagents and methods, electrical test circuits and methods, physical test components and methods, optical test components and methods, and biological test reagents and methods to yield information about a blood sample. Such methods are well known in the art and

5 may be based on teachings of, e.g. Tietz Textbook of Clinical Chemistry, 3d Ed., Sec. V, pp. 776-78 (Burtis & Ashwood, Eds., W.B. Saunders Company, Philadelphia, 1999); U.S. Pat. No. 5,997,817 to Chrismore et al. (Dec. 7, 1999); U.S. Pat. No. 5,059,394 to Phillips et al. (Oct. 22, 1991); U.S. Pat. No. 5,001,054 to Wagner et al. (Mar. 19, 1991);
10 and U.S. Pat. No. 4,392,933 to Nakamura et al. (July 12, 1983), the teachings of which are hereby incorporated by reference, as well as others. Testing means may include sensors in the sample test chamber that test electrochemical properties of the blood, or they may include optical means for sensing optical properties of the blood (e.g. oxygen saturation level), or they may include biochemical reagents (e.g. antibodies) to sense
15 properties (e.g. presence of antigens) of the blood. Said testing means may be present at, e.g., a "test site" or an "analytical site." The testing means may comprise biosensing or reagent material that will react with an analyte in the blood (e.g. glucose) so that an appropriate signal correlating with the presence of the analyte is generated and can be read by the reader apparatus. Testing means are "associated with" a chamber or other
20 structure when the testing means participates in the function of providing an appropriate signal about the blood sample to the reader device. "Calibrant testing means" refers to testing means used to test a calibrant.

"Lancet" means any sharp member used to puncture the skin for the purpose of cutting blood vessels and allowing blood to flow to the surface of the skin. The lancet
25 has certain parameters such as diameter or width to define the cross-sectional area of the member, and geometry to define the shape of the distal or front lancing end of the member. "Lancet driver" means any means for propelling the lancet to puncture the skin. Examples of lancets and lancet drivers are well known in the art and are described herein with relation to the invention.

25 The term "embossing" is used to refer to a process for forming polymer, metal or ceramic shapes by bringing an embossing die into contact with a pre-existing blank of polymer, metal or ceramic. A controlled force is applied between the embossing die and the pre-existing blank of material such that the pattern and shape determined by the embossing die is pressed into the pre-existing blank of polymer, metal or ceramic. The
30 term "embossing" encompasses "hot embossing" which is used to refer to a process for forming polymer, metal or ceramic shapes by bringing an embossing die into contact with a heated pre-existing blank of polymer, metal or ceramic. The pre-existing blank

of material is heated such that it conforms to the embossing die as a controlled force is applied between the embossing die and the pre-existing blank. The resulting polymer, metal or ceramic shape is cooled and then removed from the embossing die.

The term "injection molding" is used to refer to a process for molding plastic or nonplastic ceramic shapes by injecting a measured quantity of a molten plastic or ceramic substrate into dies (or molds). In one embodiment of the present invention, components of miniaturized devices can be produced using injection molding.

References cited herein are hereby incorporated by reference in their entirety, except to the extent that they conflict with teachings explicitly set forth in this specification.

Referring to Figure 1, a blood sampling system incorporating a disposable sampling module 100 and a reader device 102 are shown. The reader device 102 includes a deck 104 having a lid 106 attached to the deck by hinges along the rear edge of the system 108. A readout display 110 on the lid 106 functions to give the user information about the status of the reader device 102 and/or the sampling module 100, or to give a readout of a blood test. The reader device 102 has several function buttons 112 for controlling function of the reader device 102 or for inputting information into the reader device 102. Alternatively, the reader device may have a touch-sensitive screen, an optical scanner, or other input means known in the art. A reader device with an optical scanner may be particularly useful in a clinical setting, where patient information may be recorded using scan codes on patients' wristbands or files. The reader device may have a memory, enabling the reader device to store results of many recent tests. The reader device may also have a clock and calendar function, enabling the results of tests stored in the memory to be time- and date-stamped. A computer interface 114 enables records in memory to be exported to a computer. The reader device 102 has a chamber located between the deck 104 and the lid 106 which closely accommodates a sampling module 100. The chamber is accessed by raising the lid 106, allowing a sampling module 100 to be inserted or removed.

Figure 2 is an illustration showing some of the features of an embodiment of a sampling module. The sampling module 100 has a housing having an orientation sensitive contact interface for mating with a complementary surface on the reader device. The contact interface functions to align the sampling module with the reader device, and

also allows the reader device to rotate the sampling module in preparation for a new sampling event. The contact interface may take the form of cogs or grooves formed in the housing which mate with complementary cogs or grooves in the chamber of the reader device. The sampling module has a plurality of sampling sites 120 on the housing, which are shown as slightly concave depressions near the perimeter of the sampling module 100. Each sampling site defines an opening 122 contiguous with a sampling port entering the sampling module. In an alternate embodiment, the sampling sites and sampling ports are located on the edge of the sampling module. Optical windows 124 allow transmission of light into the sampling module for the purpose of optically reading test results. Alternatively, sensor connection points allow transmission of test results to the reader device via electrical contact. Access ports 126, if present, allow transmission of force or pressure into the sampling module from the reader device. The access ports may be useful in conjunction with running a calibration test or combining reagents with sampled blood.

The described features are arranged around the sampling module, and the sampling module is radially partitioned into many sampling segments, each sampling segment having the components necessary to perform a single blood sampling and testing event. A plurality of sampling segments are present on a sampling module, generally at least ten sampling segments are present on a single disposable sampling module; at least about 20, or more on some embodiments, and at least about 34 sampling segments are present on one embodiment, allowing the sampling module to be maintained in the reader device for about a week before replacing with a new sampling module (assuming five sampling and testing events per day for seven days). With increasing miniaturization, up to about 100, or more preferably up to about 150, sampling segments may be included on a single sampling module, allowing up to a month between replacements with new sampling modules. It may be necessary for sampling sites to be located in several concentric rings around the sampling module (or otherwise packed onto the housing surface) to allow the higher number of sampling segments on a single sampling module. In other embodiments, the sampling module may be any other shape which may conveniently be inserted into a reader device and which are designed to contain multiple sampling segments, e.g. a square, rectangular, oval, or polygonal shape. Each sampling segment is miniaturized, being generally less

than about 6.0 cm long by about 1.0 cm wide by about 1.0 cm thick, so that thirty five more or less wedge-shaped sampling segments can fit around a disk having a radius of about 6.0 cm. Preferably, each sampling segment is much smaller, e.g. less than about 3.0 cm long by about 0.5 cm wide by about 0.5 cm thick.

5 Figure 3 depicts, in a highly schematic way, a single sampling segment, positioned within the reader device. Of course, it will occur to the person of ordinary skill in the art that the various recited components may be physically arranged in various configurations to yield a functional system. Figure 3 depicts some components which might only be present in alternate embodiments and are not necessarily all present in any
10 single embodiment. The sampling segment has a sampling port 140 which is contiguous with an opening 142 defined by a sampling site 144 on the sampling module housing 146. A lancet 148 having a lancet tip 150 adjacent to the sampling port 140 is operably maintained within the housing such that the lancet 148 can move to extend the lancet tip 150 through the sampling port 140 to outside of the sampling module. The lancet
15 148 also has a lancet head 152 opposite the lancet tip. The lancet 148 is driven to move by a lancet driver 154, which is schematically depicted as a coil around the lancet 148. The lancet driver 154 optionally is included in the sampling module (as pictured) or alternatively is external to the sampling module. The sampling segment may further include a driver port 156 defined by the housing adjacent to the lancet head 152 – the
20 driver port 156 allows an external lancet driver 158 access to the lancet 148. In embodiments where the lancet driver 154 is in the sampling module, it may be necessary to have a driver connection point 164 upon the housing accessible to the reader device. The driver connection point 164 may be a means of triggering the lancet driver 154 or of supplying motive force to the lancet driver 154, e.g. an electrical current to an
25 electromechanical lancet driver. In one embodiment a pierceable membrane 160 is present between the lancet tip 150 and the sampling port 140, sealing the lancet 148 from any outside contact prior to use. A second membrane 162 may be present adjacent to the lancet head 152 sealing the driver port 156. The pierceable membrane 160 and the second membrane 162 function to isolate the lancet 148 within the lancet chamber to maintain sterility of the lancet 148 prior to use. During use the pierceable membrane
30 160 and the second membrane 162, if present, are pierced by the lancet tip 150 and the external lancet driver 158, respectively.

A capillary channel 166 leads from the sampling port 140 to a sample test chamber 168. The sample test chamber 168 is associated with a testing means capable of being read by the reader device. If the testing means is optical in nature, the testing means may include optically transparent windows 170 in the housing above and below the sample test chamber 168, allowing a light source in the reader device to pass light 172 through the sample test chamber. An optical sensor 174, e.g. a CMOS array, is present in the reader device for sensing the light 176 that has passed through the sample test chamber 168 and generating a signal to be analyzed by the reader device. In a separate embodiment, only one optically transparent window is present, and the opposing side of the sample test chamber is silvered or otherwise reflectively coated to reflect light back through the sample test chamber and out the window to be analyzed by the reader device. In an alternate embodiment, the testing means is electrochemical 178, e.g. an enzyme electrode, and includes a means of transmitting an electric current from the sampling module to the reader device, e.g. an electrical contact 180 on the housing accessible to the reader device.

In one embodiment, the pierceable membrane 160 may be made of polymer-based film that has been coated with a silicone-based gel. For example, the membrane structure may comprise a polymer-based film composed of polyethylene terephthalate, such as the film sold under the trademark MYLAR. The membrane structure may further comprise a thin coating of a silicone-based gel such as the gel sold under the trademark SYLGARD on at least one surface of the film. The usefulness of such a film is its ability to reseal after the lancet tip has penetrated it without physically affecting the lancet's cutting tip and edges. The MYLAR film provides structural stability while the thin SYLGARD silicone laminate is flexible enough to retain its form and close over the hole made in the MYLAR film. Other similar materials fulfilling the structural stability and flexibility roles may be used in the manufacture of the pierceable membrane in this embodiment.

The pierceable membrane 160 operates to allow the lancet tip 150 to pierce the pierceable membrane 160 as the lancet tip 150 travels into and through the sampling port 140. In the described embodiment, the silicone-based gel of the membrane 160 automatically seals the cut caused by the lancet tip 150. Therefore, after an incision is made on a finger of a user and the lancet tip 150 is retracted back through the pierceable

membrane 160, the blood from the incision is prevented from flowing through the pierceable membrane 160, which aids the blood to travel through the capillary channel 166 to accumulate within the sample test chamber 168. Thus the pierceable membrane 160 prevents blood from flowing into the lancet device assembly, and blood contamination and loss into the lancet device mechanism cavity are prevented. In yet another embodiment, used sampling ports are automatically sealed off before going to the next sample acquisition cycle by a simple button mechanism. A similar mechanism seals off a sampling port should sampling be unsuccessful.

In an alternate embodiment, a calibrant supply reservoir 182 is also present in each sampling segment. The calibrant supply reservoir 182 is filled with a calibrant solution and is in fluid communication with a calibration chamber 184. The calibration chamber 184 provides a source of a known signal from the sampling module to be used to validate and quantitate the test conducted in the sample test chamber 168. As such, the configuration of the calibration chamber 184 closely resembles the sample test chamber 168. During use, the calibrant solution is forced from the calibrant supply reservoir 182 into the calibration chamber 184. The figure depicts a stylized plunger 186 above the calibrant supply reservoir 182 ready to squeeze the calibrant supply reservoir 182. In practice, a variety of methods of transporting small quantities of fluid are known in the art and can be implemented on the sampling module. The calibration chamber 184 is associated with a calibrant testing means. Figure 3 shows two alternate calibrant testing means – optical windows 170 and an electrochemical sensor 188. In cases where the sampling module is designed to perform several different tests on the blood, both optical and electrochemical testing means may be present. The optical windows 170 allow passage of light 190 from the reader device through the calibration chamber 184, whereupon the light 192 leaving the calibration chamber 184 passes onto an optical sensor 174 to result in a signal in the reader device. The electrochemical sensor 188 is capable of generating a signal that is communicated to the reader device via, e.g. an electrical contact 194, which is accessible to a contact probe 196 on the reader device that can be extended to contact the electrical contact 194. The calibrant solution may be any solution which, in combination with the calibrant testing means, will provide a suitable signal which will serve as calibration measurement to the reader device. Suitable calibrant solutions are known in the art, e.g. glucose solutions of

known concentration. The calibration measurement is used to adjust the results obtained from testing means from the sample test chamber.

To maintain small size in some sampling module embodiments, allowing small quantities of sampled blood to be sufficient, each component of the sampling segment must be small, particularly the capillary channel and the sample test chamber. The capillary channel can be less than about 0.5 mm in diameter, specifically less than about 0.3 mm in diameter, more specifically less than about 0.2 mm in diameter, and even more specifically less than about 0.1 mm in diameter. The capillary channel may generally be at least about 50 micrometers in diameter. The dimensions of the sample test chamber may be less than about 1 mm by about 1 mm by about 1 mm, specifically less than about 0.6 mm by about 0.6 mm by about 0.4 mm, more specifically less than about 0.4 mm by 0.4 mm by 0.2 mm, and even more specifically less than about 0.2 mm by about 0.2 mm by about 0.1 mm. The sampling test chamber can generally be at least about 100 micrometers by 100 micrometers by 50 micrometers. The sampling module is able to return a valid testing result with less than about 5 microliters of blood taken from the skin of a patient, specifically less than about 1 microliter, more specifically less than about 0.4 microliters, and even more specifically less than about 0.2 microliters. Generally, at least 0.05 microliters of blood is drawn for a sample.

The sample module housing may be made in a plurality of distinct pieces which are then assembled to provide the completed housing. The distinct pieces may be manufactured from a wide range of substrate materials. Suitable materials for forming the described apparatus include, but are not limited to, polymeric materials, ceramics (including aluminum oxide and the like), glass, metals, composites, and laminates thereof. Polymeric materials are particularly preferred herein and will typically be organic polymers that are either homopolymers or copolymers, naturally occurring or synthetic, crosslinked or uncrosslinked. It is contemplated herein to form portions of the sampling modules of substrates including materials such as the following: polycarbonates; polyesters, including poly(ethylene terephthalate) and poly(butylene terephthalate); polyamides, (such as nylons); polyethers, including polyformaldehyde and poly(phenylene sulfide); polyimides, such as that manufactured under the trademarks KAPTON (DuPont, Wilmington, DE) and UPILEX (Ube Industries, Ltd., Japan); polyolefin compounds, including ABS polymers, Kel-F copolymers, poly(methyl

methacrylate), poly(styrene-butadiene) copolymers, poly(tetrafluoroethylene), poly(ethylenevinyl acetate) copolymers, poly(N-vinylcarbazole) and polystyrene.

The devices of the invention may also be fabricated from a "composite," i.e., a composition comprised of unlike materials. The composite may be a block composite, e.g., an A-B-A block composite, an A-B-C block composite, or the like. Alternatively, the composite may be a heterogeneous combination of materials, i.e., in which the materials are distinct from separate phases, or a homogeneous combination of unlike materials. As used herein, the term "composite" is used to include a "laminated" composite. A "laminated" refers to a composite material formed from several different bonded layers of identical or different materials. Other preferred composite substrates include polymer laminates, polymer-metal laminates, e.g., polymer coated with copper, a ceramic-in-metal or a polymer-in-metal composite. One composite material is a polyimide laminate formed from a first layer of polyimide such as KAPTON polyimide, available from DuPont (Wilmington, Delaware), that has been co-extruded with a second, thin layer of a thermal adhesive form of polyimide known as KJ®, also available from DuPont (Wilmington, Delaware).

The invention in its various embodiments can be fabricated using any convenient method, including, but not limited to, molding and casting techniques, embossing methods, surface machining techniques, bulk machining techniques, and stamping methods. Further, injection molding techniques well known in the art may be useful in shaping the materials used to produce sample modules according to the instant invention.

For some embodiments, the first time a new sampling module 100 is used, the user removes any outer packaging material from the sampling module 100 and opens the lid 106 of the reader device 102, exposing the chamber. The sampling module 100 is slipped into the chamber and the lid 106 closed. The patient's skin is positioned upon the sampling site 120 and the integrated process of lancing the skin, collecting the blood sample, and testing the blood sample is initiated, e.g. by pressing a function button 112 to cause the lancet driver to be triggered. The patient's skin is maintained in position upon the sampling site 120, adjacent the sampling port 140, until an adequate volume of blood has been collected, whereupon the system may emit a signal (e.g. an audible beep) that the patient's skin may be lifted from the sampling site 120. When the testing of the sample is complete, the reader device 102 automatically reads the results from the

sampling module 100 and reports the results on the readout display 110. The reader device 102 may also store the result in memory for later downloading to a computer system. The sampling module 100 may then automatically be advanced to bring the next sampling segment inline for the next use. Each successive time the system is used (until the sampling module 100 is used up), the patient's skin may be placed upon the sampling site 120 of the (already installed) sampling module 100, thus simplifying the process of blood sampling and testing.

A method of providing more convenient blood sampling, wherein a series of blood samples may be collected and tested using a single disposable sampling module which is designed to couple to a reader device is described. Embodiments of the sampling module include a plurality of sampling segments. Each sampling segment can be adapted to perform a single blood sampling cycle and is functionally arranged within the sampling module to allow a new sampling segment to be brought online after a blood sampling cycle is completed. Each blood sampling cycle may include lancing of a patient's skin, collection of a blood sample, and testing of the blood sample. The blood sampling cycle may also include reading of information about the blood sample by the reader device, display and/or storage of test results by the reader device, and/or automatically advancing the sampling module to bring a new sampling segment online and ready for the next blood sampling cycle to begin. A method embodiment starts with coupling of the sampling module and reader device and then initiating a blood sampling cycle. Upon completion of the blood sampling cycle, the sampling module is advanced to bring a fresh, unused sampling segment online, ready to perform another blood sampling cycle. Generally, at least ten sampling segments are present, allowing the sampling module to be advanced nine times after the initial blood sampling cycle. In some embodiments, more sampling segments are present and the sampling module may be advanced about 19 times, and about 34 times in some embodiments, allowing about 19 or about 34 blood sampling cycles, respectively, after the initial blood sampling cycle. After a series of blood sampling cycles has been performed and substantially all (i.e. more than about 80%) of the sampling segments have been used, the sampling module is decoupled from the reader device and discarded, leaving the reader device ready to be coupled with a new sampling module.

Although the above-described embodiments of the present invention have been described in detail, various modifications to the present invention will become apparent to those skilled in the art from the foregoing description and accompanying drawings and will be within the scope of the invention, which is to be limited only by the following claims.

CLAIMS

1. An apparatus for collecting blood from a patient's skin, the apparatus comprising a unit housing including a plurality of sampling segments, each sampling segment comprising

5

a sampling port,

a lancet having a tip, the tip adjacent the sampling port, the lancet maintained within the housing and operable to extend the lancet tip through the sampling port to pierce the patient's skin positioned adjacent the sampling port, and

10

a sample test chamber in fluid communication with the sampling port, the sample test chamber associated with testing means.

2. The apparatus of claim 1, wherein each sampling segment further comprises a sampling site contoured for positioning the patients' skin, the sampling site defining an opening contiguous with the sampling port.

15

3. The apparatus of claim 1, wherein the unit housing includes at least 10 sampling segments.

4. The apparatus of claim 1, wherein each sampling segment is configured to allow integrated lancing, collection, and testing.

5. The apparatus of claim 1, wherein the sample test chamber is smaller than about 0.6 mm long by 0.6 mm wide by 0.4 mm deep.

20

6. The apparatus of claim 1, wherein each sampling segment further comprises a calibrant reservoir in fluid communication with a calibration chamber, the calibration chamber associated with calibrant testing means.

25

7. A blood sampling system comprising the apparatus of claim 1, the blood sampling system further comprising a reader device associated with the apparatus of claim 1.

8. The blood sampling system of claim 7 configured to allow integrated lancing of the skin, collection of blood, testing of the blood, display of information about the blood, and advancement of the apparatus of claim 1 to bring another sampling segment online.

5 9. A method of collecting and testing a series of blood samples, the method comprising

 a) obtaining a sampling module and a reader device, the sampling module including a plurality of sampling segments, each sampling segment adapted to perform a single blood sampling cycle of lancing, collection of a blood sample, and testing of
10 the blood sample,

 b) coupling the sampling module to the reader device,

 c) initiating the blood sampling cycle,

 d) advancing the sampling module to bring another sampling segment online,

 e) repeating steps c) and d) until substantially all sampling segments on the
15 sampling module have been used, and

 f) uncoupling the sampling module and reader device.

10 10. The method of claim 9, wherein steps c) and d) may be repeated at least 10 times before performing step f).

20 11. The method of claim 9, wherein each sampling segment is configured to allow integrated lancing, collection, and testing.

 12. The method of claim 9, wherein each sampling segment is configured to allow a configuration measurement to be obtained by the reader device.

1/2

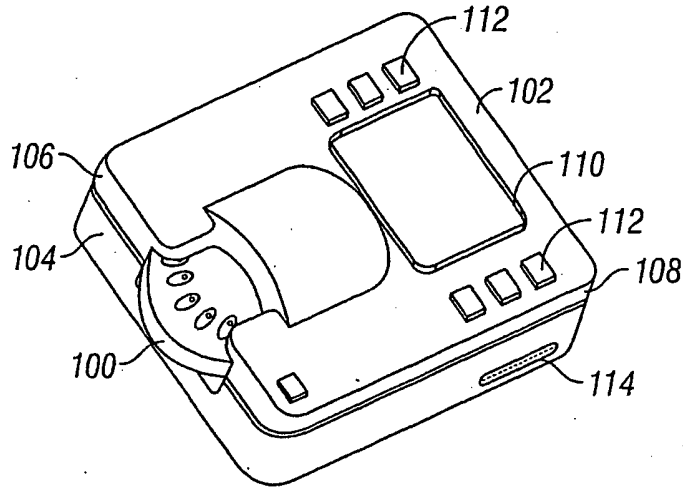

FIG. 1

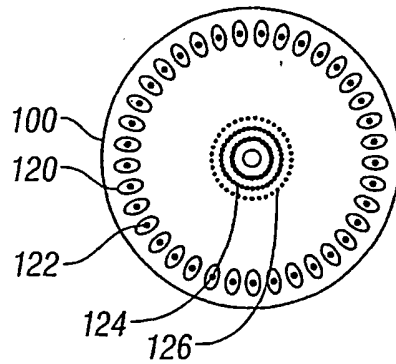

FIG. 2

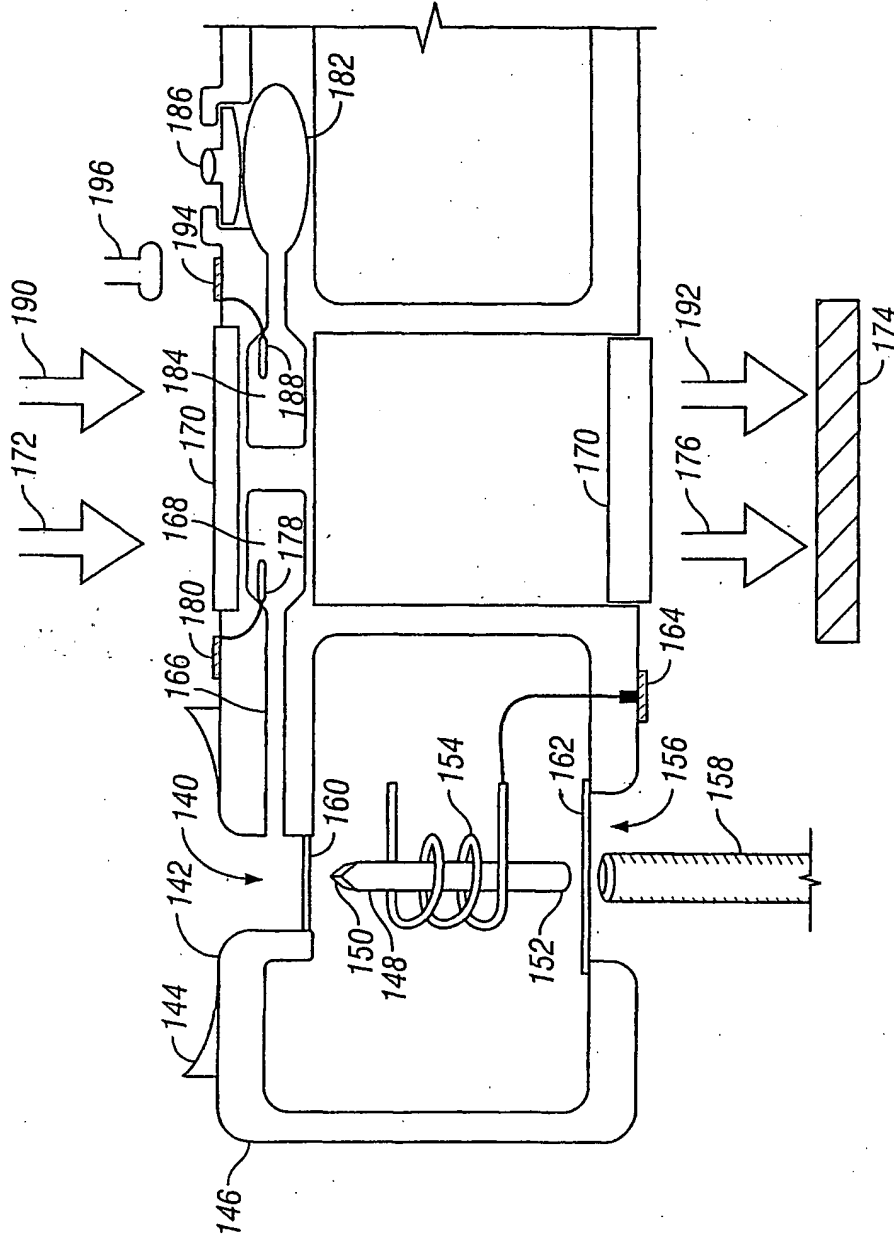

FIG. 3

BLANK PAGE